

WALL HUGGER

WALL MOUNTED AUTOMATIC LINT FILTER

**PREVENT EQUIPMENT DAMAGE, UNSIGHTLY MESS, AND
POTENTIAL FIRE FROM EXCESSIVE LINT BYPASS**



BENEFITS

- **>98% of Lint Filtered and Collected**
- **Prevents HVAC Equipment Damage from Lint Exhaust**
- **Meets EPA Standards for Particle Emission to the Air**
- **Reduces Fire Hazard**
- **Maintenance Free Design**

FEATURES

- **Lint Collection Outside of the Dryer**
- **Preset Dryer Back Pressure Controlled Automatic Blow Down**
- **"Lint Blaster" Compressed Air Blow Down**
- **UL Controls**
- **Noncorrosive Fiberglass and Aluminum Construction for Long Life**
- **Non-Stick "Black Fiberglass" Interior Surface Prevents Lint Build Up within the Filter**
- **Fine Mesh Filter Screen**

OPERATING PRINCIPLES

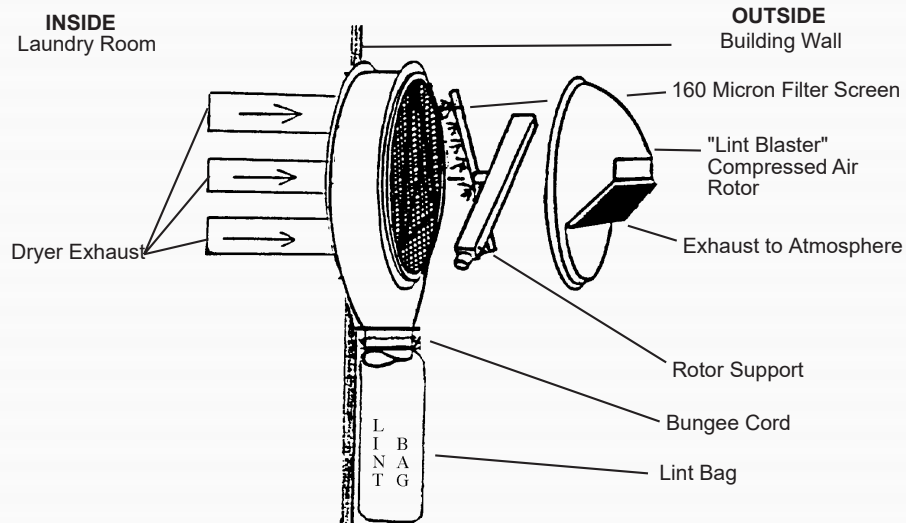

1. Lint is exhausted from the dryer(s) through the wall and collects on the screen.
2. At pre-set back pressure, determined by dryer exhaust CFM, compressed air is released. The compressed air activates the rotor and automatically "blasts" the lint off the screen.
3. Lint drops by gravity into the lint bag.

	#35	#60	#80	#140
CFM Capacity	3,500	6,000	8,000	14,000
A Height	55"	76"	90"	102.5"
B Depth	34"	41"	43"	46.5"
C Width	48"	66"	77"	88"
Weight (lbs)	75	160	210	300

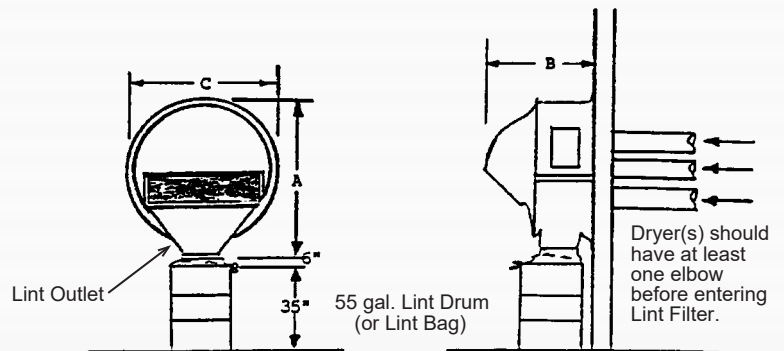

EASY INSTALLATION

- Easily retrofitted to existing site
- Mounts flush with side of building over existing duct penetrations
- Filters are painted to match existing color scheme

Contact Energenics Corp. for the name of your authorized distributor.



800-944-1711



sales@energenics.com | energenics.com

