

# UV-MAX

## MOBILE - UVC SURFACE DISINFECTION

**LAB-TESTED EFFICACY DEMONSTRATING 99.99+% ELIMINATION OF BACTERIA & VIRUS**

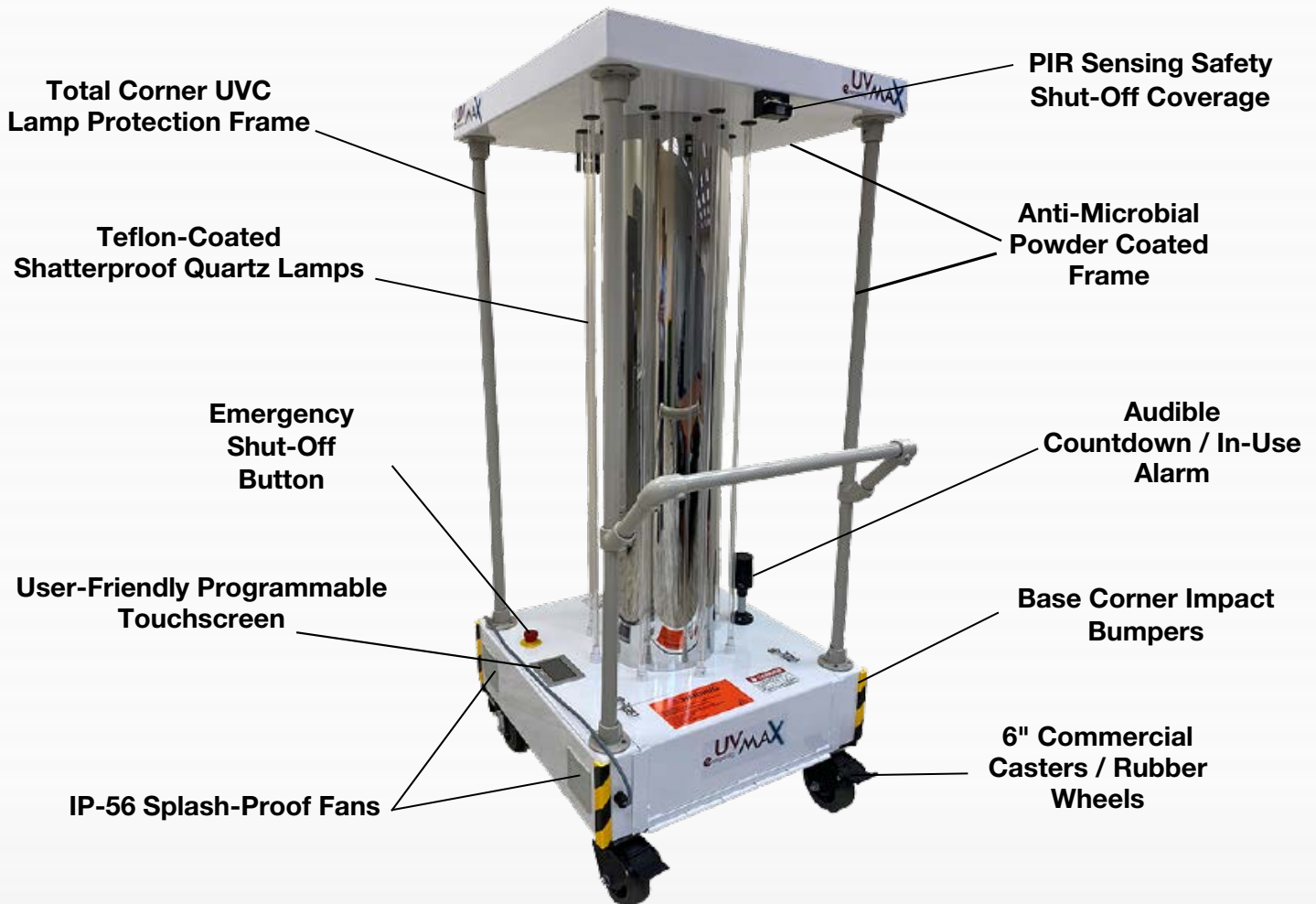

### APPLICATION EXAMPLES

- \*Linen Transport Vehicles
- \*Surgical Pack Rooms
- \*Nursing Homes / Senior Centers
- \*Offices & Work Stations
- \*Hospitals / Medical Facilities

- \*Restaurants / Hotels
- \*Operations Centers
- \*Locker / Break Rooms
- \*Prisons / Jails
- \*Churches / Shelters

- \*Manufacturing Facilities
- \*Gym / Fitness Centers
- \*Schools / Lecture Halls
- \*Police Dept. / Firehouses
- \*Airports / Mass Transit Hubs

## UV-MAX SPECIFICATIONS

Total Watts:	880 Watts
UV-C Output:	320 Watts
Wavelength:	254nm
Amp Draw:	8 amps
Input Volts:	120v AC
Lamp Type:	LP, High-Output
Lamp Qty:	8
Lamp Length:	54 Inches
Lamp Life:	15,000 Hours
PIR Sensor(s):	Yes (2)
Distribution:	360 Deg.
Touchscreen:	Yes
Audible Alert:	Yes
Wheel/Caster:	6: (2-Locking)
Dimensions:	30"x30"x73"H
Weight:	200 lbs
Efficacy:	99.99+%
Controls:	UL Rated
Warranty:	2-Years

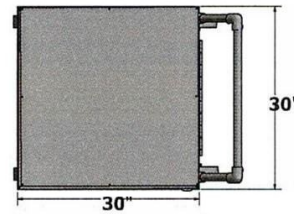

TOP VIEW UV-MAX AND  
UV-MAX LOW PROFILE

Operating Wt: 200 lbs  
Shipping Wt: 495 lbs

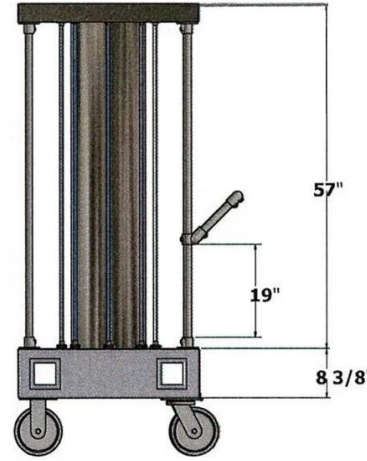

SIDE VIEW UV-MAX

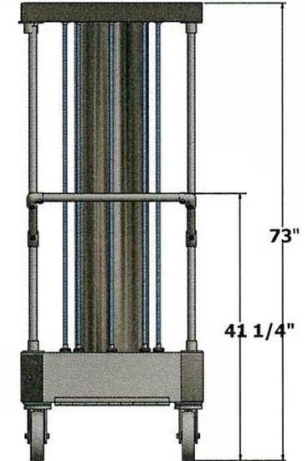

REAR VIEW UV-MAX

## UV-MAX UVC Dose Guidelines

UVC Watt Output			ULTRA & MAX 320		MAX LP 240		ECO 175	
Feet From Target (Max w/ Device Placed Center of Room)	Room Dims	Square Foot of Room	Minutes to Kill Bacteria/Virus	Minutes to Kill Spores	Minutes to Kill Bacteria/Virus	Minutes to Kill Spores	Minutes to Kill Bacteria/Virus	Minutes to Kill Spores
1			1	2	1	3	2	4
2			1	2	1	3	2	4
3			2	3	3	5	4	7
4	8 x 8	64	2	3	3	5	4	7
5	10 x 10	100	2	4	3	5	4	7
6	12 x 12	144	3	6	4	8	5	11
7	14 x 14	196	3	6	4	8	5	11
8	16 x 16	256	4	8	5	11	7	15
9	18 x 18	324	4	8	5	11	7	15
10	20 x 20	400	5	10	7	13	9	18
11	22 x 22	484	6	12	8	12	11	22
12	24 x 24	576	6	12	8	16	11	22

The above listed treatment times are based on widely acceptable inactivation dose levels of 50,000  $\mu\text{Ws}/\text{cm}^2$  (bactericidal) or 100,000  $\mu\text{Ws}/\text{cm}^2$  (sporicidal). It is offered as a reference point,

**LEARN MORE  
ABOUT OUR  
"TOTAL PLANT  
DISINFECTION"  
PRODUCTS BY  
CALLING OR  
VISITING US ONLINE!**

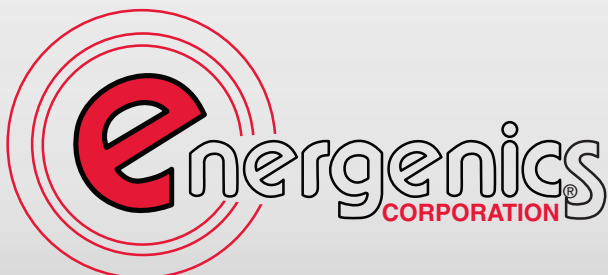

1470 Don Street  
Naples, Florida  
34104  
USA

T: 800.944.1711  
E: sales@energenics.com  
W: www.energenics.com  
EPA EST. NO. 96474-FL-1