

# AFO-6

## AirFlow Optimizer Fan Package

### Features:

- Variable frequency drive (VFD)
- Pressure transducer
- Tubeaxial booster fan & motor

### Benefits:

- Maintains optimal airflow minimizing dry time
- Corrects dryer inefficiencies / conserves energy
- Fully automated (after setup)

### Utility Requirements:

- 208v or 480v (specify); 60 Hz; 3-phase
- Independent electrical source required

### Fan Specifications:

- Drive: Belt
- Motor: 2hp; 1,735 rpm
- Max BHP: 1.98
- Fan RPM: 1,688
- Sones @ 0.250-in. SP @ 5' - 43
- Motor enclosure: enclosed / fan cooled
- Motor height: 10-inch
- Shaft diameter: 1-inch
- Blades: 6; aluminum
- FLA: 6.0-5.4/2.7
- Max inlet temp: 200 deg F
- Max ambient temp: 104 deg F
- Bearing: ball
- Mounting: vertical/horizontal
- Housing: steel; baked enamel finish

### CFM

- @ 0.000-in. SP - 9,112
- @ 0.125-in. SP - 8,856
- @ 0.250-in. SP - 8,573
- @ 0.500-in. SP - 7,983
- @ 0.750-in. SP - 7,290
- @ 1.000-in. SP - 6,445

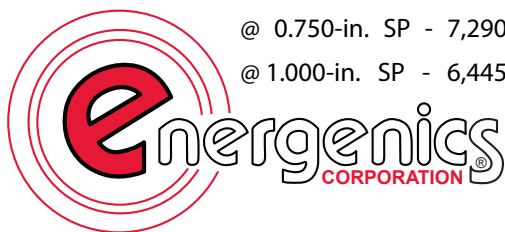

AFO - SERIES



Variable Frequency Drive, Fan, & Transducer

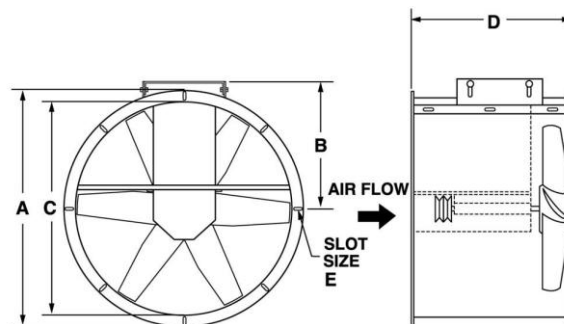

### Dimensions

- A: 27"
- B: 16-3/4"
- C: 24-5/16"
- D: 18"
- E: 7/16"

INLINE SPACE SAVER TYPICAL INSTALLATION WITH AIRFLOW OPTIMIZER OR BOOSTER FAN

