

AFO-30

AirFlow Optimizer Fan Package

Features:

- Variable frequency drive (VFD)
- Pressure transducer
- Tubeaxial booster fan & motor

Benefits:

- Maintains optimal airflow minimizing dry time
- Corrects dryer inefficiencies / conserves energy
- Fully automated (after setup)

Utility Requirements:

- 208v or 480v (specify); 60 Hz; 3-phase
- Independent electrical source required

Fan Specifications:

- Drive: Belt
- Motor: 10hp; 1,750 rpm
- Max BHP: 9.04
- Fan RPM: 891
- Sones @ 0.250-in. SP @ 5' - 112
- Motor enclosure: enclosed / fan cooled
- Motor height: 12-1/2-inch
- Shaft diameter: 1-7/16-inch
- Blades: 5; aluminum
- FLA: 27.2-24.6/12.3
- Max inlet temp: 200 deg F
- Max ambient temp: 104 deg F
- Bearing: ball
- Mounting: vertical/horizontal
- Housing: steel; baked enamel finish

CFM

- @ 0.000-in. SP - 38,100
- @ 0.125-in. SP - 37,140
- @ 0.250-in. SP - 36,105
- @ 0.500-in. SP - 33,885
- @ 0.750-in. SP - 31,380
- @ 1.000-in. SP - 28,550
- @ 1.250-in. SP - 24,060

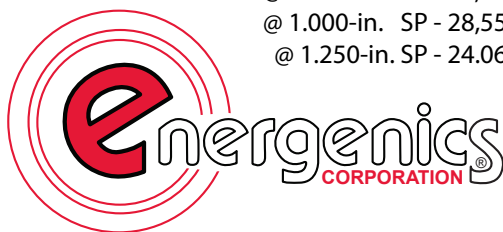

AFO - SERIES



Variable Frequency Drive, Fan, & Transducer

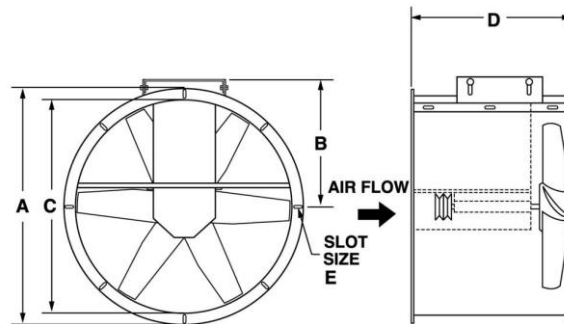

Dimensions

- A: 51-3/4"
- B: 28-5/16"
- C: 48-1/2"
- D: 36"
- E: 9/16"

INLINE SPACE SAVER TYPICAL INSTALLATION WITH AIRFLOW OPTIMIZER OR BOOSTER FAN

