

FRP-10

In-line Space Saver Lint Collector

Standard Features:

- 10,000 CFM capacity
- UL Class 2 fire retardant fiberglass
- UL508a PLC control
- Air solenoid valve for blow-down
- (3) Built-in logic methods for blow-downs
- Large access door
- Lint screen
- Lint collection bag
- Support legs
- Left hand inlet (shown); right available

Optional Features:

- Side discharge (rotates 360°)
- Fire suppression system (FSS)
- Excess pressure alarm
- Inlet collars
- Compressed air storage tank
- Pre-plumbing & pre-wiring
- Magnahelic pressure gauge
- Additional radius inspection door: contact for available locations & as-built drawings
- Variable speed air flow optimizer (for long or undersized duct runs)
- Lint drum w/ flexible connector

Utility Requirements:

- 120/240v Single phase; 1.3/.65FLA
- 30ft³ Compressed air per blow-down (2.5 SCFM compressor load)
- 1" Compressed air connection
- 1" Cold water connection for FSS (8 gpm when activated)



FRP SERIES



FRP filter w/ optional radius inspection door and compressed air storage tank

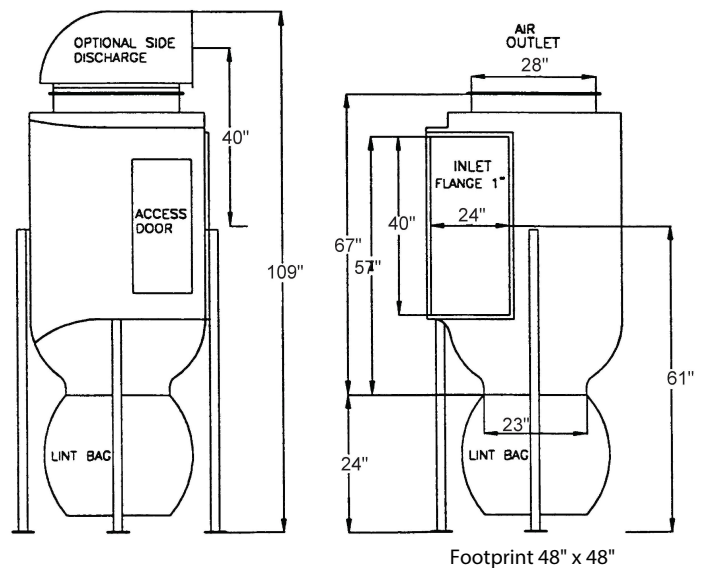
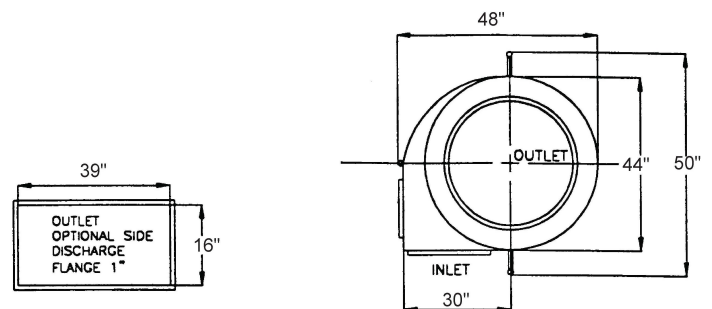

Footprint 48" x 48"