

LS-8000 / LS-6000

AMBIENT AIR LINT FILTERS

TRUE AIR SCRUBBERS REMOVING LINT, DUST, AND CONTAMINANTS FROM THE AIR



LINT SCRUBBER 8000



LINT SCRUBBER 6000

FEATURES AND BENEFITS

- Continuously attracts and captures lint, dust, and other contaminants created by everyday processing / operations
- Easily positions over machinery and processes that create secondary lint and dust
- Utilizes pressure transducer control technology to advance the filter media for optimum automated lint extraction
- Helps protect expensive automated processing equipment resulting in reduction of daily cleaning and maintenance costs
- Pulls contaminants and hot air away from associates while exhausting upward to blow lint / dust from overhead pipes and fixtures for future capture
- Assists with compliance in OSHA Combustible Dust National Emphasis Program directive CPL 03-00-008
- Antimicrobial powder-coat over heavy gauge aluminum construction

SPECIFICATIONS

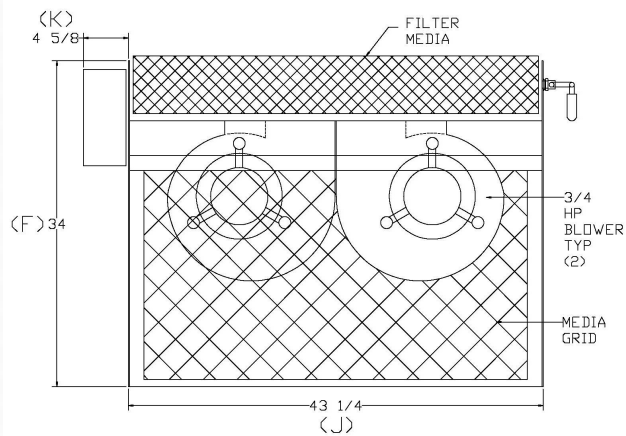

SIDE VIEW

(LS-8000)

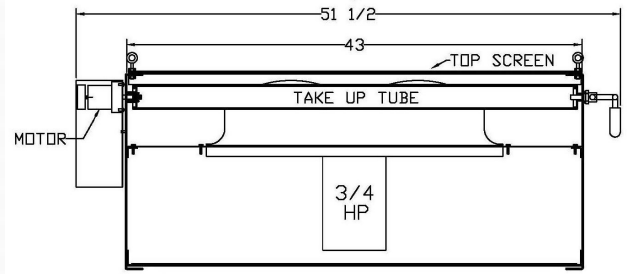

SIDE VIEW

(LS-6000)

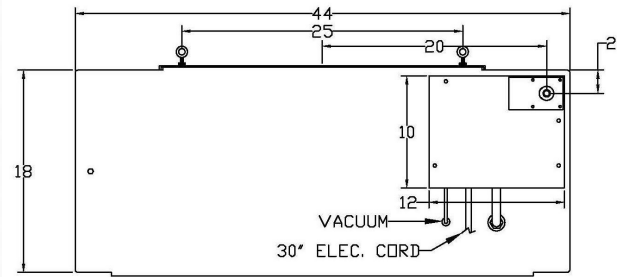

END VIEW

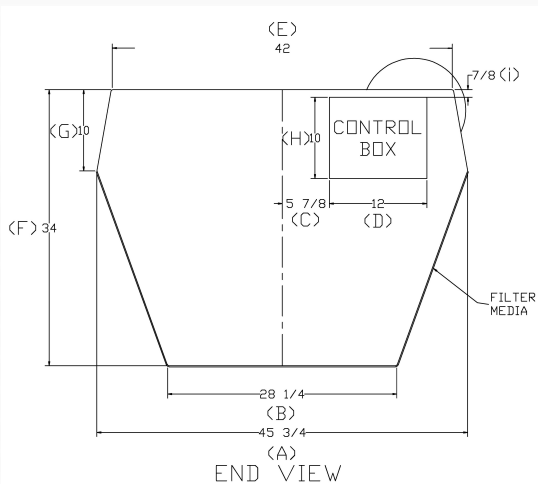

END VIEW

**UV-C LIGHT
OPTIONS AVAILABLE**



LINT SCRUBBER 8000 W/ UV-C

TECHNICAL INFORMATION

- Solid State UL Controls
- Optimum Flat-bonded Polyester Screen Media
- Voltage 208-230/60/1 VAC 11.5 amps (Standard)
- 480/60/3 Available
- LS-8000: 8,000 CFM, 800 sq ft area, ~280 LBS
- LS-6000: 6,000 CFM, 600 sq ft area, ~240 LBS

Lint Scrubbers arrive completely assembled.

Hang up, plug in, catch contaminants.



800-944-1711



sales@energenics.com | energenics.com

